

MOUNTING HOLE(2/1)

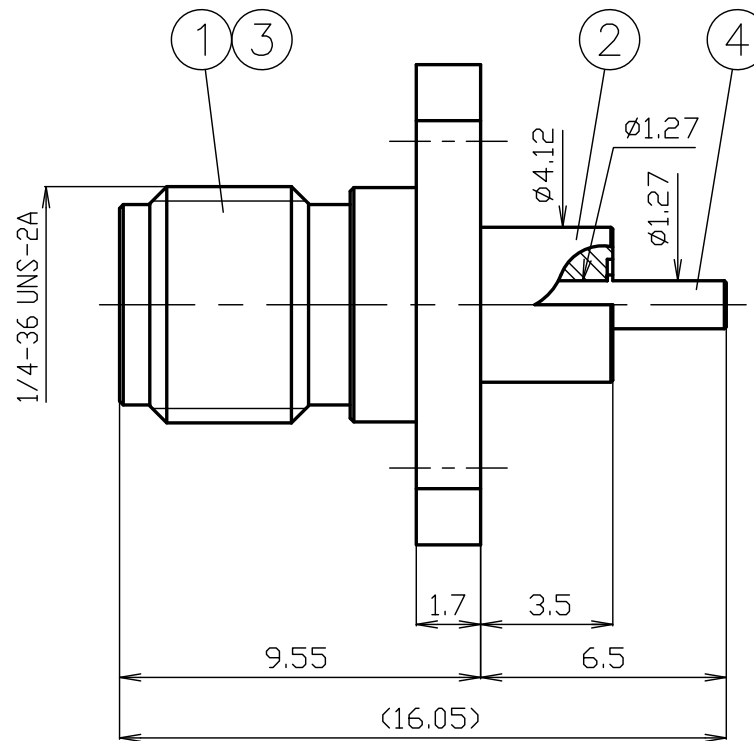

※1 : BERYLLIUM COPPER

RoHS Compliant [Cd ≤75ppm]
 REMARKS BRASS: Cd ≤75ppm
 PHOSPHOR BRONZE: Pb <4wt%

NO.	DESCRIPTION	MATERIAL	Q'TY	FINISH	REMARK	SCALE	DRAWN	INSPECTED	APPROVED	CHECKED	PART NUMBER
7						5/1	井	石	檜	三	SMA-R-S
6							'26.03.12	'26.03.12	'26.03.12	'26.03.12	
5						mm	出	川	澤	村	
4	CENTER PIN	※1	1	Au							
3	BUSHING	BRASS	1	Ni		DATE	PROJECTION				
2	INSULATOR	PTFE	1	--		2026.03.12					
1	BODY	BRASS	1	Ni							DRAWING NO. X-1136889

■Part number : SMA-R-S

■Drawing number : X-1136889

■Nominal

Standard : JEITA RC-5234

Voltage rating : AC 500V

Rated frequency : 18GHz

Impedance : 50Ω

Operating temperature range : -40°C~+85°C

Operating humidity range : 95% Max. ※No condensation

■Structural shape : Conformity with the drawings.

■Electrical

Test Items	Test Method/Value	Remarks
Insulation resistance	5000MΩ Min. at DC 500V	
Withstanding voltage	1 minute at AC 1000V	
Contact resistance	Inner conductor : 3mΩ Max. Outer conductor : 2mΩ Max.	
VSWR	DC~18GHz : 1.2 Max.	

■Mechanical

Test Items	Test Method/Value	Remarks
Compatibility	No defects or abnormalities	Connecting with a standard compliant connector
Tensile strength of coupling mechanism	180N	At axial tensile force
Center contact captivation	5N Min.	At axial tensile force
Center contact retaining force	0.28N Min.	With a standard pin gauge
Mounting strength	98N	

■Revisions

No.	Date	Contents
1		
2		

Date	Name
2026/03/12	井出(Prepared)
2026/03/12	石川(Inspected)
2026/03/12	檜澤(Approved)
2026/03/12	三村(Checked)