

# Reference Drawing

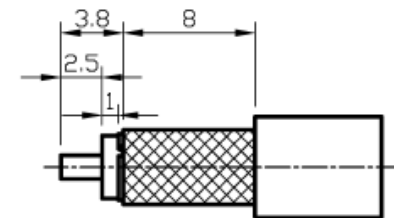
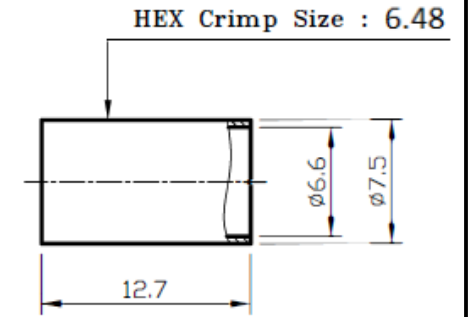
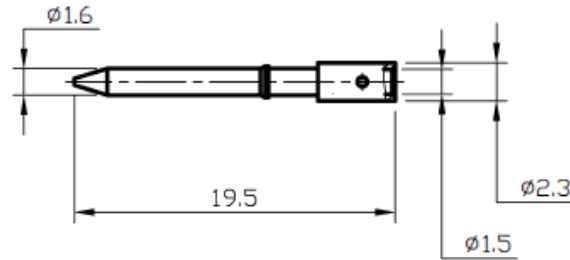
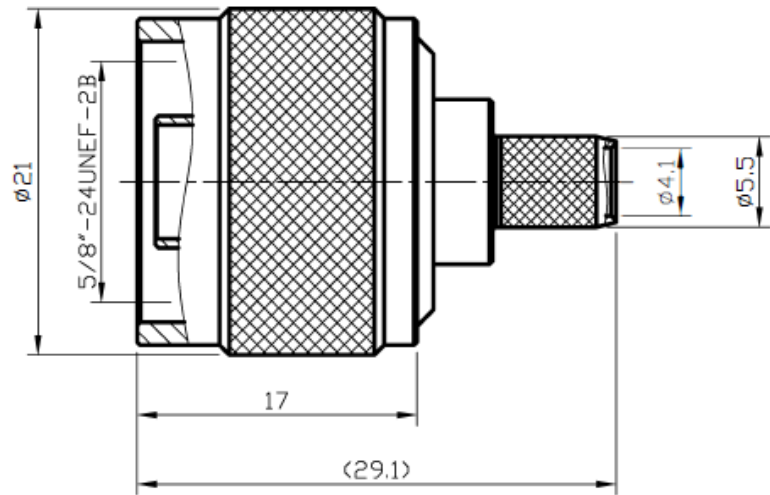

STRIP LENGTHS (REF)

NO	DESCRIPTION	MATERIAL	QTY	FINISH
8	FERRULE	BRASS	1	NICKEL
7	CENTER PIN	BRASS	1	GOLD
6	CABLE BODY	BRASS	1	NICKEL
5	INSULATOR	TEFLON	1	---
4	BODY	BRASS	1	NICKEL
3	INNER RETAINING RING	BRASS	1	---
2	GASKET	SILICONE	1	RED
1	SHELL	BRASS	1	NICKEL

NOMINAL IMPEDANCE : 50Ω  
 FREQUENCY RANGE : DC ~ 6GHz  
 VSWR : 1.3 MAX  
 For LMR240/H155 Cable

RoHS Compliant		Cd ≤ 75ppm
REMARKS	BRASS: Cd ≤ 75ppm PHOSPHOR BRONZE: Pb < 4wt%	

SCALE NONE		PART NUMBER
UNIT mm		NP-LMR240A
DATE 2025/10/20	PROJECTION 	TO-CONNE CO.,LTD